

Elementary Campus

Grades K-8

Academic Requirements for Participation in Athletics

Academic Eligibility

Elementary and Middle School students must maintain a “C” or better in all academic classes and an “S” or higher in all special classes and all areas of conduct.

All students are assessed at progress report time and at the end of each grading period in grades 5-8.

Mid-Quarter Progress Report

All students must earn a “C” or better in all academic classes and an “S” or higher in all special classes and all areas of conduct. Those that do not will be allowed to practice but NOT PLAY in scheduled games. Students should not attend games either. Middle School students with a “D” or “F” must attend Study Hall each Wednesday from 3:15-4:00 until the end of the quarter. Students may resume eligibility at the end of the grading period, if the grades on the report card are in good standing. If the student fails to follow policies, he or she may be asked to withdraw from the team. If the student fails to follow policies, he or she may be asked to withdraw from the team. If the student fails to follow policies, he or she may be asked to withdraw from the team.

Report Card Assessment of Progress

All students must earn a “C” or better in all academic classes and an “S” or higher in all special classes and all areas of conduct. Failure to do so will result in the student being ineligible from both practice and games until the next progress report is issued.

Attendance on Game Days

A student must attend five sequential class periods on the day of a scheduled or make-up athletic event.

After School Care / Student Supervision

Elementary campus students will not be allowed to wait unsupervised on school property, outside the school, or in the hallways or the gym after dismissal for their ride. **The school is not liable for any harmful action that occurs after school hours if a child is not in the after school care program.**

An after school program is available on campus under the direction of Associated Catholic Charities.

Any elementary campus student in grades K-8 who is not picked up by 3:15 p.m. will go immediately to the after school program. On Thursdays the pick up time is 2:00 p.m., students in grades K-8 not picked up by 2:15 p.m. will go immediately to the after school program. Parents/guardians are responsible for the fees charged. Students who are not picked up on time consistently will be required by the principal to register for the after school program. Associated Catholic Charities reserve the right to dismiss any student from the ASC Program for disruptive behavior.

High school students may pick-up elementary campus students at dismissal from their assigned dismissal location. The parent/guardian of the high school student and elementary student(s) must submit acknowledgement and permission for the student to be picked up by the high school student to the elementary student’s teacher. The teacher will take it to the office where it will be placed in the student’s file along with their Pick-up Authorization Form. High school students participating in this dismissal procedure will be responsible for the supervision of the student entrusted to their care. If this student is found unsupervised on the school campus the school may revoke the privilege of this dismissal provision and require the student to be placed in the After School Care program directed by Catholic Charities. The parent/guardian will be responsible for the fees charged. Students who participate in sports or other school related activities must be picked up at the designated time and place.

Arrival and Departure Procedures

ICCS uses a carpool drop-off and pick-up system for students in grades K-5. Drivers enter the school parking lot from York Avenue and drop the students off in the horseshoe (the parking area between the main elementary building and the parish office). Supervised Safety Patrol is available to assist children from the car and into the building. Middle School students, grades 6-8, are dropped off at Kearney Hall.

The school doors open at 7:30 a.m. for student arrivals. Teachers are assigned a morning duty schedule to supervise the students arriving between 7:30-7:45 a.m.

School begins promptly at 8:00 a.m. Students should be in their classroom, ready to start the day when the 8:00 a.m. bell rings. Any student arriving after 8:00 a.m. **must be accompanied by the parent/guardian** to obtain a tardy slip from the school office. The tardy slip will be given to the Homeroom teacher as admission into the classroom. The teacher will keep the tardy slip on file.

All middle school students who arrive late will be checked in through the elementary office. After checking in with the office, the parent/guardian will drop the student off at the middle school building in Kearney Hall by the brick wall. If a parent fails to accompany the student into the elementary office an automatic warning notice will be sent home to be signed. This will be followed by a phone call to the parent.

Elementary students may be dropped off in the horseshoe (the parking area between the main elementary building and the parish office) between 7:30-7:45 a.m. Supervised safety patrol will assist the children out of the car and into the cafeteria. At 7:45 a.m. a teacher will gather the students from the cafeteria and lead them to their classrooms. Students arriving between 7:45-7:55 a.m. should walk to their classrooms.

Grades K-5

Students in grades K-3 arriving before 7:45 a.m. must go to the cafeteria and wait at their homeroom's assigned table for their teacher to take them to the classroom. The K-3rd grade classroom teachers will escort their students from the cafeteria to the classroom at 7:45 a.m.

Students in grades 4-5 arriving before 7:45 a.m. go to the cafeteria. At 7:45 they will walk to their classrooms.

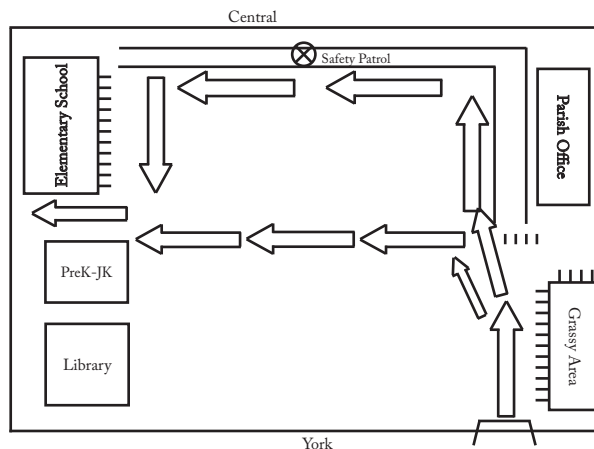

Middle School

Students in grades 6-8 arriving before 8:00 a.m. may go directly to their locker to pack and prepare for their day. They should then immediately report to their homeroom.

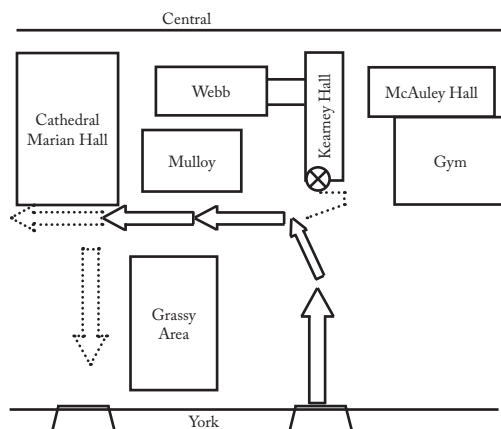

Daily Dismissal for Grades K-8

School will dismiss for students in grades K-8 as follows:

Mon.	Tue.	Wed.	Thur.	Fri.
3:00 p.m.	3:00 p.m.	3:00 p.m.	2:00 p.m.	3:00 p.m.

All other early dismissals are announced or published in school correspondence, calendars, and on the website.

The following are important Arrival and Departure notices and reminders:

- Students may not be picked up by their ride from the median on Central Avenue.
- Middle school students are not allowed to be picked up on the Central Avenue side of campus. Middle school students will be picked up by Kearney Hall in the parking lot or in the horseshoe.
- Students walking home from school should have a pre-determined route with their parent, guardian, or caregiver.
- Students needing to cross Central Avenue should do so with the assistance of the crossing guard located at the Central and Belvedere intersection.
- **Parents should not park in any part of the horseshoe at anytime.**
- Parents should not leave their vehicle at any time while in the horseshoe. This is for the safety of the students, the Dismissal Attendant, and the parents. Dismissal is not a time to have discussions with teachers.
- When exiting the parking lot onto Rozelle please notice that there is no right turn in the morning OR in the afternoon.
- The East-side of Rozelle is a No Parking area.

Attendance and Tardiness

Regular and prompt attendance is a school requirement and is essential for students' academic success and promotion. A student must have a pattern of regular attendance and must arrive on time in order to obtain the full benefit of the academic program. Excessive absences or repeated tardiness handicaps the individual student and has a negative effect on those who make the effort to be on time for school. A student is considered tardy if not unpacked and seated in their homeroom or class by 8:00 a.m.

Appropriate reasons for a student's absence or tardiness include illness, emergency, bereavement for a family member, religious observance, medical or legal appointment that cannot be rescheduled. Absences or tardiness for reasons other than those listed above will be excused at the discretion of the administration. Any absence or tardiness affects the Perfect Attendance Award. All elementary students must maintain zero absent and tardy (excused or unexcused) status to obtain a "Perfect Attendance" award. Early outs will count against Perfect Attendance.

The following policy outlines procedures to ensure efficiency and convenience for the administration and faculty to monitor daily attendance:

- Parents of elementary students in grades K-8 must notify the school by 8:00 a.m. using the Attendance Phone Line 901-435-5284 if their child will be absent, late, or required to leave school early. Parents/guardians must provide written notice to the teacher acknowledging a student's absence upon the student's return to school. The teacher will keep these notes on file. This document is necessary should a discrepancy in the student's attendance record arise during the school year. The documentation will be destroyed at the end of the school year.
- Class work must be requested in conjunction with the attendance notice. Class work or homework assignment and books may be picked up in the school office at the end of the day. Books and assignments for Middle School students should be picked up from their homeroom teacher at the end of the day.
- As a courtesy, a parent or guardian must notify the school in writing of a planned absence. These absences will be excused at the discretion of the administration based on the reason and length of the absence, and the student's academic and attendance records. Students who are absent for unexcused reasons will be given make-up work only upon their return.
- Detentions are assigned on the fourth tardy and each even occurrence thereafter for the quarter. Excessive tardiness may result in other disciplinary actions.
- The principal shall view attendance records and initiate appropriate actions in accordance with the school-wide Discipline Policy to address student absences and tardiness. Students deemed to be truant will be reported to the truancy office in accordance with state law.

Cafeteria Service

Our cafeteria service or lunch program is provided through Sodexo. Students may purchase a hot lunch or other food choices available from the cafeteria or bring a lunch from home. Students in Pre-K through second grade are served the prepared hot lunch without choices. Meal tickets are available through the cafeteria manager. Students may also purchase food or drinks with cash. If a student does not have a lunch or lunch money, the student will be given a light lunch. Parents are invited to eat lunch with their child.

Cheating

Cheating of any type will not be tolerated. Students who choose to cheat face a failing grade, detention, suspension and/or expulsion. In the Middle School the student is given a zero on the assignment, a detention (Level II), and the parent is contacted.

Child Abuse Laws

ICCS abides by the Child Abuse Prevention, Adoption, and Family Services Act. This law mandates that all cases of suspected abuse and/or neglect be reported to Child Protective Services.

Cell Phones and Electronic Devices

Students are not prohibited from bringing electronic devices to school but they are strongly discouraged from doing so. If electronic devices must be brought to school, ICCS and its faculty and staff are not responsible for devices that are lost, damaged or stolen.

Elementary school students may keep cell phones and electronic devices in their backpacks during the day. All devices must be turned off and may not be accessed during the day. Failure to follow policy will result in a demerit for the student and the device will be taken to the office and must be picked up by the student's parent.

Middle school students must sign in their cell phones to their homeroom teacher upon entering the classroom. Devices must be turned off and may not be accessed during the day unless given permission by the teacher. Failure to follow policy will result in a Level II detention. Students may have their devices back at the end of the school day. The teacher will lock up electronic devices left behind overnight.

E-readers (Kindle, Nook, etc)

E-readers are not allowed in the elementary school.

E-readers may be used in the middle school, provided that students use them appropriately. They may only be used during free-reading times and should not be used to play games. Classroom teachers reserve the right to take up or ask students to put them away if they become a distraction or are used inappropriately. Failure to follow policy will result in a Level II detention. ICCS also reserve the right to ask specific students not to bring devices to school if they cause a repeated disturbance in the classroom.

Laptop & Tablet computers (iPad, Xoom, etc)

Students should not bring laptop or tablet computers to school. If these devices must be brought to school, they should be turned into the homeroom teacher in accordance with the cell phone policy. Failure to do so will result in a Level II detention.

Other electronic devices

Students are strongly discouraged from bringing unneeded electronic devices to school. However, should the student need to bring it to school, they should put it away before entering the building. In middle school, students should turn these devices in to their homeroom teacher upon entering the classroom in accordance with cell phone policy. Failure to do so will result in a Level II detention. Other devices include but are not limited to hand-held gaming devices (Nintendos, Playstation etc), music devices (iPods, mp3 players etc), and cameras. All devices should be turned off when given to the teacher. *ICCS administration, faculty and staff are not responsible for any electronic devices brought to school by students and will not be accountable if the devices are lost, stolen or damaged.*

Miscellaneous

Field trips – use of electronic devices on field trips is at the discretion of the organizing teacher(s).

Headphones – Students should not plug headphones into computers during lab times to stream music or audio for 'back ground noise/music.' Doing so utilizes network bandwidth and slows down the entire campus network. Headphones are provided in the lab if students are instructed to use them.

Other personal items – Classroom teachers reserve the right to 'hold on to' for safe keeping other personal items brought from home that are not needed during the school day. These will be returned at the end of the day. Personal items include but are not limited to musical instruments (except for music class), skateboards and scooters, athletic equipment, clothing or overnight bags and materials for projects in other classes. ICCS personnel are not responsible for personal items if they are lost, stolen, or damaged.

Communication between Parents and Teachers

It is our objective to be accessible to parents in an effective and efficient manner. There are a number of avenues to maintain communication between home and school including:

1. Report cards
2. Agenda books
3. Conferences
4. HSA
5. Wildcat Wire
6. Calendars
7. Voicemail
8. Progress reports
9. E-mail
10. PowerSchool
11. Myiccs.org website

ICCS requires a parent-teacher conference at the conclusion of the first grading period (Quarter 1). The teacher, parent, counselor, or principal may request additional conferences. Parents wishing a conference should contact the student's teacher.

Contact Information

Parents are requested to notify the school office in writing of any changes of email address, telephone numbers, addresses and emergency contacts so that office records may be accurate, complete, and up to date.

Custody Records

The school office should be provided with current custody papers if these papers pertain to visitation or pick-up authorization of a parent or individual. The school must have a copy of custody papers in order to enforce.

Discipline

The main objective of the school is to create a positive, structured atmosphere in which each student can thrive academically and exhibit proper behavior and self-control. In order to provide a successful learning experience it is important to establish consistent classroom procedures and guidelines for behavioral expectations. The following are campus-wide discipline procedures for grades K-8 that will ensure students are able to learn in a safe and nurturing environment.

Building and Playground –General Conduct

Each person is asked to keep the school and the grounds clean and in good condition. Rules of the building and playground include:

- Students should not play in the front yard or behind or between parked cars.
- If the students need to leave their class or playground, they will walk in pairs at all times on campus.
- No one is allowed to leave the playground without permission from an authorized adult.
- Respect and good sportsmanship must be displayed to all on campus.
- Bicycles are to be locked to the bicycle stand. No child is to take another's bicycle from the bicycle stand. Cyclists should wear a proper safety helmet.
- Gum chewing is not permitted on school grounds. Students caught chewing gum during the school day will be issued a demerit.

Discipline Policy for Kindergarten-5th grade

Depending on the infractions, students in grades K-5 who choose not to follow the rules of the ICCS campus will face detention, ISS (In-School Suspension), and OSS (Out-of-School Suspension). Kindergarten and first grade students who choose to engage in serious offences will be immediately referred to the administration. Depending on the severity of the offense, students may be asked to stay home for a day or more. Students who bite or leave a mark on another child will be sent home for the day. This will not be considered an OSS; instead, it is an alternative consequence for our younger students. Student will be expected to complete assignments during this time away from school. Repeated behaviors may result in students being placed on Disciplinary Probation.

Other options available to the K-5 teachers include, but are not limited to loss of recess time, silent lunch, or additional written assignments.

Discipline Policy for Middle School

Teachers will assign demerits for infractions of school rules such as tardiness, excessive talking, disruptive behavior, chewing gum, out of uniform, missing assignments, etc. Each homeroom teacher tracks the demerits daily throughout the year.

Teachers may assign automatic detentions for major infractions of rules such as leaving the classroom without permission, inappropriate words or gestures, disrespect toward a teacher, another student, or staff member, foul

language, spitting, bullying, not turning in electronic devices, forgery, disrespect for others or property, or cheating/plagiarism.

A teacher may refer a student directly to administration in the event that a situation is serious and warrants immediate intervention. The outcome will be at the discretion of the Administration and may result in a detention, In-School Suspension (ISS), Out of School Suspension (OSS), or expulsion.

Merit/Demerit System

ICCS strives to spotlight the students whose actions build and strengthen our community. These students will have the opportunity to earn merits from all teachers across the campus and be celebrated for choosing to be model citizens of our school.

Students in grades K-8 use the following scale for citizenship grades:

S= Satisfies Expectations

N= Needs Improvement

U=Unsatisfactory

ICCS uses a demerit system for discipline. Upon earning two detentions a student's citizenship grade will drop to the next letter.

Detention and ISS (In-School Suspension)

Earning seven demerits will result in a Level 1 detention. Level 2 infractions will result in an automatic detention, while Level 3 infractions will result in an ISS or OSS. Detention may also be assigned at the discretion of the administration. Detentions are held from 3:00-4:00 p.m. on Mondays unless otherwise noted. Detention takes precedence over appointments, practices, lessons, etc.

An ISS may result when a student misses an assigned detention. Any student who earns two or more detentions in a quarter will receive an In-School Suspension and be on Disciplinary Probation. Students are not allowed to participate in any school-sponsored extracurricular activities on days they have served an ISS.

OSS (Out-of-School Suspension)

Out-of-school suspensions will only be assigned for serious disciplinary offenses. The number of days assigned to OSS is at the discretion of the administration. All school assignments are to be turned in at the end of the OSS. During an OSS, students are not allowed to participate in any school-sponsored extracurricular activities. A student serving an OSS is ineligible to receive honor roll during that quarter.

Disciplinary Probation

Disciplinary Probation is a serious consequence that may be assigned to any students in any grade. Disciplinary Probation is a time for students to focus on making better choices in regard to their conduct. While on Disciplinary Probation, students will meet with the school counselor to work on skills that will allow them to better contribute to the learning environment of their school community. If during the Disciplinary Probation period a student earns additional demerits, additional consequences will be at the discretion of the administration. Terms of Disciplinary Probation will be determined by the administration.

Referrals

When a student continues to struggle with his/her conduct choices, a conference with the family and the school counselor will be scheduled. In order to best serve the student and to protect the learning environment in every classroom, an evaluation may be recommended. If the evaluation recommends counseling or an intervention program, a student's continued enrollment will be contingent upon following said recommendations.

Dismissal and Expulsion

A student will be asked to withdraw from school if his/her conduct is such that the learning community at ICCS

is no longer beneficial to the child, if the student continues to be disruptive to the learning community, or if the student poses a possible threat of harm to other students. Expulsion . .

Off Campus Behavior

Students will remember that they are representatives of ICCS at all times, even when they are off campus or on-line. If a student's conduct and choices reflect detrimentally on the school, disciplinary actions may be taken by the administration.

ICCS reserves the right of the administration to waive and/or deviate from the disciplinary regulations for just cause.

Drugs and Alcohol

Students who possess drugs and/or alcohol at school or at any school function will face suspension or expulsion.

Emergency Drills

State Law requires that fire drills be held monthly and tornado and earthquake drills held periodically. All safety drill procedures are reviewed with students prior to the actual drill. Students must remain silent and follow all directions during an emergency drill.

Field Trips

School field trips must have the approval of the school principal and are to be of an educational nature. Children must turn in a signed permission slip provided by the school. A note or email from the parent will not take the place of the form. Parent drivers must complete a Volunteer Driver Form. Volunteer Drivers must provide appropriate insurance on their vehicles. Volunteer Drivers are required to refrain from smoking, drinking alcoholic beverages, and using improper language while on a school fieldtrip. All volunteer drivers **MUST** have completed VIRTUS training and they must have another VIRTUS trained adult with them in the car (see the VIRTUS Training handbook). All students must wear a seatbelt or provide an appropriate booster seat and must not share a seatbelt. Parent drivers are not permitted to take side trips from the designated destinations. Participation on a field trip is a privilege, not a right. Students . .

Grading

Parents/guardians have constant access to their child's grades and progress through PowerSchool, a username and password protected on-line site. Teachers are required to update student grades weekly. PowerSchool provides parents/guardians the option to receive weekly emails on their child's progress and attendance and school bulletins.

Academic Grade Scale

A	=	93-100
B	=	86-92
C	=	76-85
D	=	70-75
F	=	Below 70
I	=	Incomplete
NG	=	Not Graded

Non-Academic Grade Scale

E	=	Excellent
G	=	Good
S	=	Satisfies Expectations
N	=	Needs Improvement
UP	=	Unsatisfactory Progress

Handbook Amendments/Issues Not in Handbook

The school reserves the right to amend the policies in this handbook at the discretion of the principal. Any changes to the handbook will be communicated to parents/guardians.

If an issue should arise which is not expressly discussed in the handbook, the principal will handle the situation using her professional judgment and the guiding principles of the school.

Health

ICCS does everything possible to ensure a safe, healthy environment for students and teachers. In order to keep our students and staff healthy, students *must* be healthy prior to arriving at school.

Parents are required to pick up their child if the child's temperature reaches 100 degrees. Children cannot return to school until free of an elevated temperature for 24 hours. ICCS will not distribute temperature-reducing medicines and will not allow the child to return to the classroom.

Students with a fever, rash, deep cough, diarrhea, or vomiting within the last 24 hours may not attend classes. Students must be symptom free for 24 hours before being allowed to return to school.

If a student exhibits symptoms of illness, a parent/guardian will be called to take the child home and they must remain at home for at least 24 hours. Students with consistently runny noses due to allergies will need a doctor's note stating that the symptoms are not contagious.

In addition it is imperative that the school monitor contagious illnesses. Please report any communicable illness such as chicken pox, measles, mumps, strep throat, head lice, etc. to your child's teacher and the school office immediately.

If lice or lice eggs (nits) are found on a child or a child has pink eye or any other contagious illness, the child will need to leave immediately and provide proof of treatment before being allowed to return to school.

Homework

Homework is a necessary part of a child's education. Homework is usually started under the supervision of the teacher and is completed by the student at home or in After School Care. Homework may include class work that was not completed during the school day. The amount of study time and effort will vary depending on the individual student. Cooperation between home and school will ensure fulfillment of this requirement.

Weekly folders go home for students in grades K-5. Parents are to review the student's work and return the folder with their signatures.

Any student who does not complete their homework consistently may face disciplinary action.

Honor Roll

At the end of each grading period, students will be recognized for their accomplishments.

To be eligible for first or second honors, a student must meet the following conduct requirements:

- 3rd-8th grade: S in citizenship in all academic and specialty classes

First honors are awarded to elementary campus students in grades 4-8 who have all A's in their academic subjects and have met the citizenship requirements. Grade 3 students who meet the all A's and citizenship requirements will receive a First honors award for Quarters 3 and 4 (the second semester of the school year).

Second honors are awarded to elementary campus students in grades 4-8 who have all A's and B's in their academic subjects and have met the citizenship requirements. Grade 3 students who meet the all A's and B's and citizenship

requirements will receive a Second honors award for Quarters 3 and 4 (the second semester of the school year).

Items Not Allowed at School

For all students, items such as, but not limited to, questionable books and pictures, white-out, knives, guns, matches, cigarettes, toys, trading cards, laser lights, or anything that will detract from a learning environment are not allowed at school.

The school administration, in accordance with state laws, will determine the appropriate disciplinary measures to be taken concerning the presence of these items in the school. Any items that are taken away from students will be returned to the parents/guardians.

Immunizations

All students entering school at ICCS must provide proof of immunizations to the school. Students entering Kindergarten must provide proof of immunizations on the State required State of Tennessee Health Department Immunization Record (Temporary or Permanent). ICCS is required to file a report with the state of those students who do not meet this requirement. This record is available from the child's personal physician's office or from the Health Department provided you can supply them with your child's shot records. Without this original record on file in the school office you may be asked to withdraw your child from our school.

Make-up Work

Following an absence or missed class it is essential that the student consult their teacher/s in order to arrange for make-up work. This is the responsibility of the student. The student will be expected to complete all missed assignments.

Tests and make-up work must be arranged with the teacher. Incomplete work must be made up in a timely manner as determined by the teacher and communicated with the student.

Medications

Prescription drugs and over-the-counter (OTC) medicine should be dispensed by a parent or guardian and should be taken at home. Only when the medicine must be dispensed more often than three times a day or with lunch should the school be involved. Medicine must be brought in the original container.

The Prescription and Over-the-Counter Medicine Authorization form must be completed before any prescription or OTC medication will be dispensed by the school.

If a doctor prescribes an OTC medication that must be taken at school, the following procedure should be followed:

1. A physician's authorization written on a prescription pad is required for each medication. The authorization must include the name of the medicine, amount of dosage, times to be given, and how long this particular medicine is to be administered to the student. The school will accept no verbal authorizations from the parent, guardian, or physician.
2. The parent should bring the over-the-counter medication to the office in the original, labeled container. The container must display the student's name.
3. Students may not distribute or receive medications or OTC drugs from each other.
4. Parents may come to school to administer medication.

Phone Use

The school's office phone is used for school business. Students may use the phone for urgent cases only. Students may only use the classroom phone with teacher permission.

Record Keeping

Elementary campus teachers take attendance at the beginning of the school day. Tardy students must check in with

the school secretary. Students must check out with the school secretary when leaving school early. The secretary will amend student's attendance record for Tardy and Early Out in the school's permanent attendance files.

Report Cards

A report card is provided at the end of the terms (Quarters 1, 2, 3, and 4) for JK and Kindergarten students. PowerSchool Quick Lookups are provided at the end of Quarter 1, during the Parent-Teacher Conference, for students in grades 1-8. Grades are available to parents, guardians, and students in grades 1-8 electronically through PowerSchool with the exception of the one-week period following the end of each term: Quarters 1, 2, 3, and 4, during which time administrative processes are performed and term grades are stored to the student's file.

Request for Paperwork

At least one week's notice should be given in writing for any requests for letters of recommendation, transcript requests, or evaluation forms for doctors, etc. This will give the administration and faculty enough time to properly prepare paperwork. There is a fee of \$5.00 to complete the transcripts. Transcripts cannot be processed if there are any unfulfilled financial obligations to the school.

Retention

After accessing first semester grades, parents of students who are in danger of retention will meet with teachers and administration in January with frequent follow-ups afterwards for the rest of the school year. Students on Academic Probation will meet more frequently.

Students who fail Language Arts or Math will be required to attend summer school. A student who fails Language Arts and Math will be retained. A student who fails three or more subjects, regardless of subject, will be retained or asked to withdraw from ICCS.

School Safety/Harassment

Verbal, written, or online threats made against the physical or emotional well being of any individual are taken seriously. Students making such threats seriously or in jest will be sent to the principal and face detention, suspension, and/or expulsion. Harassment of any type is not tolerated. The principal investigates all complaints of harassment. Students involved in harassing behaviors face detention, suspension, and/or expulsion.

School Property

The parent of a child who carelessly destroys or damages any furniture, equipment, buildings, or anyone's personal property will be obligated to pay the full amount of repairs and labor or replacement. Textbooks belonging to the school that are used by the student must be properly covered. The parent is responsible for replacement of damaged or lost textbooks.

Service Hours: Elementary Families

ICCS elementary campus families are encouraged to contribute a minimum of 20 service hours to the school; these are per family hours, not per student hours. Service hour forms are available from the school office or on-line. You are responsible for completing the service hour form to reflect your activities and for filing this form with the elementary office. In lieu of service hours, a \$100.00 donation to the school can be made and turned into the elementary office. The intention of the service hour program is to encourage the participation and involvement of all ICCS families in the activities on and around the campus. Through the fulfillment of service hours, we hope to promote a sense of community on the campus. Service hours are earned by participating in any of the school's activities and events. Service hours are awarded for events/activities such as: Home and School Association (HSA) Officers or Committee Chairpersons, VIRTUS Training, Coaches, Assistant Coaches, Advisory Council Members, Scout Leaders, Homeroom Parents, etc. Service hours can also add up by volunteering at school in various ways such as helping with a field trip, attending a HSA meeting, helping in the school library, lunch duty, recess duty, clean-up days, helping in school office, etc.

Service Hours: Eighth grade Students

Eighth grade students must complete 24 hours of service in order to graduate. These hours may be performed in their church, school or community. It is the student's responsibility to keep up with their service hour status and file the appropriate service hour forms with school administration. All student service hours are due in early April.

Snow Days

The Superintendent of the Catholic School System will make the final decision on suspending classes in the event of inclement weather. Suspension of school and/or early dismissal due to inclement weather is announced on television and radio stations. Normally the Catholic School System will follow the same decision as Memphis City Schools.

Social networking sites (Facebook, Myspace, etc)

While students are not prohibited from enrolling in social networking sites at home, these sites may not be accessed on school property as per the technology use agreement.

ICCS administration and faculty reserve the right to act on information gained from social media sites if:

- The student makes disrespectful or threatening statements about ICCS, its administration, faculty or staff.
- The student makes disrespectful or threatening statements to or about other students (includes threats and bullying).
- It is felt that students are a danger to themselves or to others.

Faculty and administration may not be aware of all events that take place outside of school or online but should threats or bullying occur, school personnel should be notified by the parents or student so that it may be monitored on school property and stopped should it occur. Parents are encouraged to address these problems directly with the other student's parents first.

Parents are also encouraged to talk with their children about social networking sites and their dangers. Parents should monitor their child's online activities.

Pre-teen online guidelines (adapted from Safekids.com):

3. Do not give out personal information online (address, phone number, etc).
4. Tell parents if someone makes you feel uncomfortable online.
5. Never agree to meet someone in person that you met online.
6. Never send pictures of yourself online or through cell phones.
7. Parents and children should agree on times and limits for online usage.
8. Do not give out passwords to accounts (except to parents).
9. Parents may want to keep the passwords secret from their children to monitor social networking usage.
10. Check with parents before downloading software.
11. Be a good online citizen and do not engage in illegal activities or hurt others' feelings.

Sports Program

Grades K-8 participates in the Parochial Athletic Association (PAA) through the Diocese of Memphis. For more information or to speak with the Elementary Athletic Director, contact the school office.

Suspensions

Students given an in-school suspension will be required to report to school each day. Students may not participate in any school-sponsored activities during a suspension.

Students receiving an out-of-school suspension are not allowed on campus during the time of the suspension. Students may not participate in any school-sponsored activities during a suspension.

Students must complete all class work and tests from the days of suspension. The principal in consultation with the classroom teacher will determine the amount of credit allowed for work completed during suspension.

Testing

Standardized testing is performed annually in accordance with Diocesan directives. The date of the Iowa Tests of Basic Skills (ITBS) is set by the Diocese and is usually during the month of September. Test results are kept in the students' permanent records. A copy of the fall test results is provided to the parents/guardians. Results are discussed with parents during the Parent/Teacher Conference at the end of the first quarter.

The CogAT tests are administered to students in grades 2, 4 and 7.

A second ITBS test in math and language arts may be given in the spring. Information regarding standardized testing is communicated through the school Guidance Counselor.

Tuition and Fees

Fees and appropriate monthly tuition must be paid prior to the student attending classes.

Those financially responsible for a student's tuition and fees have the following options for fulfillment of these obligations:

1. Tuition may be paid in full and a 2.5% discount will be offered.
2. Tuition may be paid in two payments: one-half on June 1 (or the student's registration date), and one-half on December 1.
3. Tuition may be paid in monthly installments through an Electronic Funds Transfer from a savings or checking account.

Parents are held responsible for any book that is damaged or lost. All athletic uniforms are the property of the school and must be returned in good condition at the conclusion of the season.

Unpaid tuition will jeopardize the student's continued enrollment and class attendance at ICCS.

The business office may be reached at (901) 435-5340.

In accordance with Diocesan policy, the school withholds report cards and PowerSchool access will be restricted if tuition or other school fees are not current. This includes any fines owed: library, athletic uniforms returned and textbooks returned at the end of the year, fees payable to vendors supplying services to ICCS families and students such as Sodexo (the contracted lunch provider at ICCS) and Catholic Charities (the contracted after school care provider at ICCS). This does not affect student awards, but does jeopardize a graduating student's (8th grade) ability to participate in graduation/recognition (K) ceremonies or receive diplomas.

Academic records are held until financial responsibilities are fulfilled.

Uniform/Dress Code

Immaculate Conception Cathedral School contracted with Parker School Uniforms to provide the official ICCS school uniforms for our students. Grades K-8 are required to wear school uniforms daily, unless an out-of-uniform day has been announced.

Students who are not in proper uniform will be sent to the office to call home so that the correct uniform may be brought to school.

Following are the uniform guidelines by grade-level groups.

K-4th Grade

Boys: Every K-4th grade boy must have a uniform consisting of: navy pants, blue or white pique knit shirt, tan suede Buc shoes or tan Merrell “Jungle Mocs”. All clothing is available at Parker School Uniforms. The shoes, provided they are the tan suede Buc, may come from the parent/guardian’s shopping choice.

Boys may also wear the navy shorts during the warmer months. These are available from Parker School Uniforms.

Girls: Every K-4th girl must have a uniform consisting of: blue and white plaid jumper, white round collar blouse, white crew socks, and black and white Saddle Oxford shoes. These items are available at Parker School Uniforms. The shoes may be purchased from any location provided they are the black and white Saddle Oxfords.

Note: The white or blue over-blouse may not be worn with the blue and white plaid jumper.

Girls may also wear the navy shorts during the warmer months or navy pants during the cooler months with the white or blue over-blouse. They may also wear black tights with their jumper; however they must wear white crew socks with the black tights. These are available from Parker School Uniforms.

Note: Leggings are not considered tights!

Boys & Girls: Boys & girls will need to have at least one complete PE Uniform with IC logo consisting of: gray gym shirt, navy gym shorts, navy sweatshirt, and navy sweatpants. 4th grade may have a navy mesh or cotton shorts for P.E. These items are available at Parker School Uniforms. Any type of comfortable tennis shoe-type shoe may be worn.

Boys and girls may wear the navy sweatshirt with IC logo in the classroom during cold weather.

5th Grade

Boys: 5th grade boys must have a uniform consisting of: navy pants, blue or white pique knit shirt, tan suede Buc shoes or tan Merrell “Jungle Mocs.” The clothing is available at Parker School Uniforms. The shoes, provided they are the tan suede Buc, may come from the parent/guardian’s shopping choice.

Boys may also wear the navy shorts during the warmer months. These are available from Parker School Uniforms.

Girls: 5th grade girls must have a uniform consisting of: blue and white plaid skirt, white or blue over-blouse, white crew socks, black and white Saddle Oxford shoes. These items are available at Parker School Uniforms. The shoes may be purchased from any location provided they are the black and white Saddle Oxfords. A navy sweatshirt w/IC logo may be worn in the classroom during cold weather.

Girls may wear black tights with their skirts; however they must wear white crew socks with the black tights. These are available from Parker School Uniforms.

Note: Leggings are not considered tights!

Boys & Girls: Boys & Girls will need to have at least one complete PE Uniform with IC logo consisting of: gray gym shirt, navy mesh or cotton shorts, navy sweatshirt, and navy sweatpants. These items are available at Parker School Uniforms. Any type of comfortable tennis shoe-type shoe may be worn.

Boys & girls may wear the navy sweatshirt with IC logo in the classroom during cold weather.

6-8th Grade

Boys: All 6-8th grade boys must have a dress uniform consisting of: khaki pants, white button-down oxford shirt with a uniform navy tie with white stripes, tan suede Buc shoes or tan Merrell “Jungle Mocs”. Middle school boys may not wear shorts. The clothing is available at Parker School Uniforms. The shoes, provided they are the tan suede Buc, may come from the parent/guardian’s shopping choice.

On days when dress uniform is not required, boys should wear the white or blue knit IC polo with the khaki pants. These are available from Parker School Uniforms. Only white T-shirts may be worn under uniform shirts.

Girls: All 6-8th grade girls must have a uniform consisting of: blue and white plaid skirt, white or blue over-blouse, white crew socks, black and white Saddle Oxford Shoes. These items are available at Parker School Uniforms. The shoes may be purchased from any location provided they are the black and white Saddle Oxfords. The skirt must be mid-knee length or longer. Only white undergarments may be worn under the blouse.

Girls may wear black tights with their skirts; however they must wear white crew socks with the black tights. These are available from Parker School Uniforms.

Note: Leggings are not considered tights!

Boys & Girls: Boys & Girls will need to have at least one complete PE Uniform with IC logo consisting of: gray gym shirt, navy mesh shorts, navy sweatshirt, and navy sweatpants. These items are available at Parker School Uniforms. Any type of comfortable tennis shoe-type shoe may be worn. A navy sweatshirt with IC logo may be worn in the classroom during cold weather.

Additional optional Items are available at Parker School Uniforms for the comfort of your student while on the ICCS campus.

K-4th Grade

Navy Sweater Vest
Navy Polar Fleece Jacket
Navy Windbreaker Jacket
Navy sweatshirt w/ IC logo

5-8th Grade

Navy Sweater Vest
Navy Polar Fleece Jacket
Navy Windbreaker Jacket
Navy sweatshirt w/ IC logo

Note: Jackets, sweaters, and sweatshirts other than those from Parker School Uniforms will not be permitted on campus. Sweatshirts and other items purchased from the IC spirit shop are not part of the school uniform.

GENERAL UNIFORM RULES

- Boys’ haircuts must be above eyebrows, ears, and off the collar. A notice may be sent home for hair that is too long.
- Hair accessories must be uniform color, blue, or white.
- Students may not wear nail polish, artificial nails, or make up.
- Tattoos of any kind and hologram contact lenses are not permitted.
- Extremes of hair are not allowed for boys or girls. Extremes of hair are defined as:
 - o Boys may not have spikes, tails, mohawks, and shaved designs in hair, ponytails, hair coloring or bleaching.
 - o Girls may not have hair over the eyes, hair coloring or bleaching.
- Only girls may wear earrings. Girls may wear stud or small earrings in the ear lobe. No hoop earrings or dangling earrings are permitted. One earring per ear only. No other body piercing is permitted. Any

jewelry worn by girls must be limited and in good taste. If jewelry becomes a distraction to the class, it will be surrendered to the teacher.

- No anklets, bracelets or chokers of any kind.
- No watches with games or calculators. Alarms on watches should not be set to go off during the school day.
- All uniform items must be labeled with the student's name.
- Girls may wear navy sweat pants on cold days to and from school and during recess on cold days. Pants under the uniform skirt or dress are not permitted at other times during the school day.
- The uniform should be clean and pressed with all buttons attached and the hem intact. Shirtsleeves should remain buttoned during the school day.
- Only single, white shoelaces may be worn with saddle oxfords and tan for boy's shoes.
- Absolutely no writing of any kind on shoes will be accepted.

On "out-of-uniform days" modest, tasteful clothing is required. Short-shorts, halters, tattered clothing, pajama pants, sandals, or flip-flops are unacceptable for school.

Use of School Grounds

The playground, gym, and field are not to be used after school hours by students without the principal or pastor's permission. Parents should not allow their children to play on the playground, in the gym or on the field without proper adult supervision.

The cafeteria may be used for special events when scheduled and approved by the school administration (i.e. Scouts).

VIRTUS Training

In order for parents/guardians to be actively involved on campus (coaching, field trips, recess duty, helping in the classroom, etc.) they must complete a VIRTUS training course through the Diocese of Memphis. A listing of class offerings can be found at: <http://www.cdom.org>. A copy of your certificate must be filed in the elementary office.

Visitors During the School Day

All school visitors (parents and guests) are requested to report to the school office upon entering the school. Visitors are asked to sign in and wear a visitor's badge while on the premises and sign out when leaving. In the event of an emergency the visitor's sign in is critical to ensuring everyone's safety.

Should you need to contact a teacher during school hours, it is recommended that email be used. All teachers' email addresses are listed in this handbook. Calls to the teacher's phones during the day will be answered by voicemail and will be checked during non-class time by the teacher. Conferences should be arranged by making an appointment with the teacher.

No child is to leave the school without permission from the office. Elementary campus students must be signed-out through the school office by an adult if they are leaving early. Middle school students will be picked up on the brick wall on the south side of Kearney Hall after they have been signed out of the elementary school office.

Students will remain in their classrooms until the secretary calls for them after an adult has signed them out. If you are picking up your child early, please allow 5-10 minutes for the secretary to contact the child's classroom and for the child to pack up their books.

All business is to be handled through the school office between 7:30 a.m. and 4:00 p.m. Monday-Friday.

All tuition issues are handled through the school business office located in the parish office building.

Middle School Schedule of Class Periods

Monday, Tuesday, Wednesday, Friday

First bell – start of school 8:00

Homeroom 8:00-8:10

1st period 8:15 – 9:00

2nd period 9:05 – 9:50 (Mass on most Tuesdays)

Break 9:50 – 10:05

3rd period 10:10 – 10:55

4th period 11:00 – 11:45

5th period 11:50 – 12:35

Lunch 12:40 – 1:15

6th period 1:25 – 2:10

7th period 2:15 – 3:00

Thursday

Homeroom 8 – 8:10

1st 8:15 – 8:55

2nd 9:00 - 9:40

Break 9:40-9:50

3rd 9:50 – 10:30

4th 10:35 – 11:15

5th 11:20 - 12:00

6th 12:05 - 12:45

Lunch 12:50 – 1:20

7th 1:25 - 2:00